

# SCANIA

SPECIFICATION

**P-series**

**P 270 CB6x4MHZ**

28500Kg GVW

THREE AXLE TIPPER

**P**

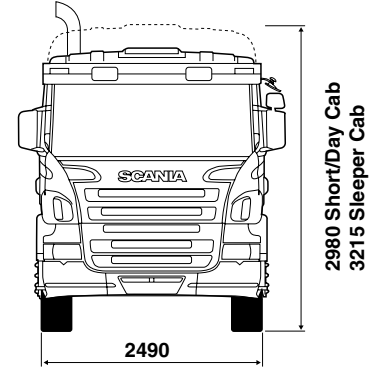
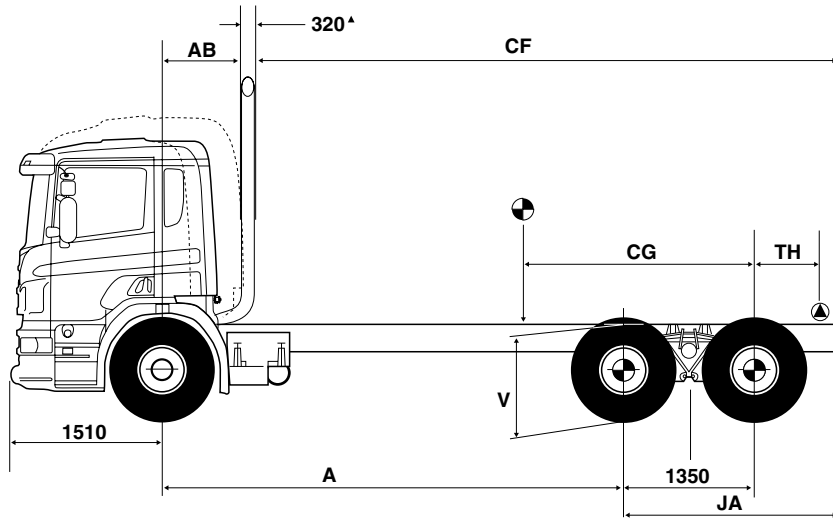

AB (centreline of front axle to back of cab) Short — 300 Day — 590 Sleeper — 860

\*Reduces to 250mm with sleeper cab

**DIMENSIONS (mm)**

<b>A</b>		3900	4100	4300
<b>BLT</b>	Day cab	5486	5945	6400
	(feet)	(18.0)	(19.5)	(21.0)
	Sleeper	5334	5563	5880
	(feet)	(17.5)	(18.3)	(19.3)
<b>CF</b>	Day cab	5200	5400	5600
	Sleeper	5000	5200	5400
<b>JA</b>		2210	2210	2210
<b>CG Max</b>	Day cab	1418	1446	1477
	Sleeper	1400	1428	1457
<b>CG Min</b>	Day cab	1292	1315	1339
	Sleeper	1274	1295	1319
<b>TH</b>		780	780	780

Frame Height	V unladen	V laden
'H'	1110 mm	1062 mm
'N'	1060 mm	1012 mm

Theoretical wheelbase (TWB) = A + 675mm.

BLT = Nominal tipper bodylength to suit weight distribution. CG dimension for body and payload calculated for standard model at standard GB plated weights. TH = Tipper hinge. V dimension measured to top of frame at rear bogie centreline.

**PLATED WEIGHTS – AWR**

		Front Axle	Rear Bogie	GVW	GTW \$
Design					
Gross	Kg	7500†	21000	28500	32000
Legal					
Max in GB	Kg	7500	19000	26000	29500

\$ With trailer brakes design = 70000kg. Max in GB = 44000kg. Rear bogie load in GB (with trailer attached) = 17000kg. † Front axle capacity up to a maximum of 9000 kg available as option. Plated weights dependent on statutory tyre limitations.

**CHASSIS/CAB WEIGHTS**

(Tolerance +/- 2.5%)

Axle distance	Front	Rear	Total (kg)
3900	4360	3300	7660
4100	4375	3305	7680
4300	4390	3360	7750

Chassis cab weight includes 20 litres of fuel, oil and water. Driver not included. See overleaf for option weights.

**P 270 CB6x4MHZ**

SL5450849  
August 06

## ENGINE (EURO 4)

Scania '9 litre' vertical five cylinder in-line turbocharged intercooled direct injection diesel, with unit injectors.

**'270'**

**Type:** DC9-17  
**Swept Volume:** 8.9 litres  
**Bore:** 127 mm  
**Stroke:** 140 mm  
**Compression Ratio:** 17:1  
**\*Max. Power:** 199kW (270 h.p.) at 1800 rev/min  
**\*Max. Torque:** 1250 Nm (922 lbf.ft) between 1100 and 1450 rev/min

**Engine Management System:** EMS incorporating Cruise Control and speed limiter

**Emission Control:** Scania EGR  
**Cooling:** Water cooled with rubber mounted 2 row radiator and electronically regulated fan

**Coolant Capacity:** 42 litres  
**Oil Capacity:** 27 litres  
**Air Cleaner:** Dry replaceable paper element

### Options:-

**(1) Details as above except for the following:-**

**'310'**

**Type:** DC9-18  
**\*Max. Power:** 228kW (310 h.p.) at 1800 rev/min  
**\*Max. Torque:** 1550 Nm (1143 lbf.ft) between 1100 and 1350 rev/min

**(2) Provision for ED120 engine driven P.T.O.**

\*With fan at max. slip

## CLUTCH

**Type:** Single dry plate  
**Operation:** Air assisted with clutch wear protection

## GEARBOX

**Type:** Scania GR905 eight speed synchromesh (four speed main fitted with two speed planetary range unit), plus one crawler gear.  
**Oil Capacity:** 15.6 litres

## GEAR RATIOS

Crawler 16.41:1

### Low Range

1st 10.34:1  
2nd 7.19:1  
3rd 5.08:1  
4th 3.75:1

### High Range

5th 2.76:1  
6th 1.92:1  
7th 1.35:1  
8th 1.00:1

Reverse 14.78:1

### Options:-

**(1) Type:** Scania GRS0905 fourteen speed range change/splitter including 2 crawler gears and overdrive top gear – only with '310' engine and hub reduction rear axles.

## REAR AXLES

**Type:** Both Scania AD1300  
**Capacity:** 26000 Kg  
Pressed steel housing with magnetic oil drain plugs.

### Option:-

**(1) Type:** Both Scania AD1101P for hub reduction axles.  
**Capacity:** 23000Kg

## REAR AXLE GEAR

**Type:** Scania RB662 - first axle  
R660 - second axle

Single reduction hypoid in both axes. Crown wheels and pinions matched during manufacture. Pneumatically operated inter-axle and cross axle differential locks.

### Options:-

**(1) Type:** Scania RBP735 - first axle  
RP735 - second axle

Single reduction spiral bevel plus epicyclic hub reduction.  
Overall ratios - 3.67 / 3.93 / 4.22

## FRONT AXLE

**Type:** Scania AM900 I section rigid beam - 'H' chassis.

Scania AM920 I section rigid beam - 'N' chassis

**Capacity:** 9000Kg

## STEERING

**Type:** Recirculating ball. Hydraulically assisted power steering

**Steering wheel:** Diameter 450mm. Lock to lock 4.9 turns

**Turning circle:** Kerb to kerb  
3.9m A/D 17.2m 4.1m A/D 17.8m 4.3m A/D 18.5m

## SUSPENSION

**Type Front:** Semi-elliptic parabolic springs with swinging shackles and threaded shackle pins damped by double acting telescopic shock absorbers.

**Type Rear:** Two spring balance beam bogie fitted with rubber mounted radius arms and double acting telescopic shock absorbers.

### Options:-

**(1) Rear or front and rear anti-roll bar(s) – rear N/A with tipper specification.**

## SPRING SIZE

	Front	Rear
<b>Length:</b>	1820mm	1530mm
<b>No. of leaves</b>	2 x 32mm	4 x 41mm
<b>Design Capacity</b>	7500Kg	21000Kg

### Option:-

**(1) Semi-elliptic parabolic springs front (3 x 29mm) - 8500kg capacity.**

**(2) Semi-elliptic parabolic springs front (4 x 28mm) – 9000kg capacity.**

## WHEELS & TYRES

**Front:** 9.00 x 22.5 ten stud spigot mounted disc wheels fitted with 315/80R22.5 radial tubeless tyres.

**Rear:** 8.25 x 22.5 ten stud spigot mounted disc wheels fitted with 295/80R22.5 radial tubeless tyres.

**Options:- (1) 11.75 x 22.5 wheels with 385/65R22.5 tyres - front axle only. (2) Aluminium wheels - machined or polished surface finish. (3) Front wheel embellishers**

## FRAME

**Type:** F950-50

Flat top constant depth 'U' channel with riveted crossmembers

### Sidemember Dimensions:

270 x 90 x 9.5mm

Rear of chassis prepared for tipper hinge.

Width over parallel section of frame = 770mm

**Bumper:** Pressed steel

**Option:- (1) Brackets for front end tipping ram - N/A with sleeper cab. (2) F958 - 'H' duty class. (3) Aerodynamic bumper incorporating FUP – reduces front overhang to 1460mm. (4) Centre tow-pin – steel bumper only.**

## BRAKE SYSTEM

**Type:** Dual circuit, full air, EC brake system incorporating category 1 ABS. Brake pipes manufactured from either rust protected steel or high impact synthetics

**Service Circuit:** Actuates all truck brakes

**Secondary Circuit:** First position of park brake lever actuates spring chambers on front and first rear axle.

**Parking Brake:** Actuates spring chambers on front and first rear axle.

**Exhaust Brake:** Air actuated operated by brake pedal

**Brake Antifreeze Protection:** Air dryer

**Brake Wear Adjusters:** Automatic

**Options:-** (1) Scania hydraulic retarder  
(2) 2 line EC trailer brake pipes to rear section of chassis.  
(3) Traction Control anti-slip device

## BRAKE DIMENSIONS

<b>Front Axle:</b>	Size 413 x 178mm Area 1640cm <sup>2</sup>	<b>Rear Axle 1:</b>	Size 413 x 203mm Area 1880cm <sup>2</sup>
<b>Rear Axle 2:</b>	Size 413 x 203mm Area 1880cm <sup>2</sup>	<b>Total Area:</b>	Service 5400cm <sup>2</sup> Parking 3520cm <sup>2</sup>

## ELECTRICAL SYSTEM

**Type:** 24V neg (-ve) earth      **Alternator:** 100A

**Batteries:** Twin 140Ah  
Rear H.I. lamps, Reversing lights

**Options:-** (1) 180Ah batteries,  
(2) 225Ah batteries,  
(3) Bodywork electrical preparation – see separate document.

## FUEL TANK

1 x 300 litre steel RHS

**Options:-** (Minimum axle distance and suspension type in brackets)

	RH Side	LH Side	RH Side	LH Side
<b>Steel - G</b>	150	150	<b>Aluminium - W</b>	200
	200	200		200
	300	300		300
	450	450 (4300Z)		350
				500 (4100Z)
				600 (4300Z)
				700

Tank sizes can be supplied in LH + RH combinations of the above but steel and aluminium cannot be mixed. Sides viewed from rear.

## GENERAL EQUIPMENT

Vertical exhaust outlet  
Front tow pin

**Options:-**  
(1) ADR to EXIII/EXIII, FL, OX or AT

## INSTRUMENTS & CONTROLS

Two man, 1 day, EC digital tachograph, rev-counter, gauges for air pressure (2), coolant temperature and fuel. Six speed wipers with four jet integral screen wash. Halogen headlamps adjustable from cab for correction of beam height. Warning lights for all major systems grouped within easy vision.

Instrument panel of modular design with switches and controls grouped according to usage. All instruments are back-lit and non-reflective. Impact absorbing, adjustable steering wheel with column lock.

## CAB

**CP16** Day Cab  
Please see separate specification – 'Scania Cabs' for equipment levels.

**Options:-**  
(1) CP19 Sleeper Cab  
(2) CP14

## P.T.O. OPTIONS Check gearbox availability

	G670	GR875/GRS895	GR905/GRS905	GRS0905
<b>EG551CC/561:</b>	6	0.54		
<b>EG650CC/660:</b>	5		1.00/1.24H	
<b>EG651CC/661:</b>	5		1.28/1.58H	
<b>EG652CC/662:</b>	5			0.82/1.03H
<b>EG653CC/663:</b>	5			1.03/1.29H
<b>EG654CC/664:</b>	5	1.00/1.24H		
<b>EG655CC/665:</b>	5	1.28/1.58H		
<b>EK730CC/740:</b>	12	1.00	1.00	1.00

CC = close coupled    H = High on 'S' splitter gearboxes only  
Shaft output N/A on 6 x 2/4 chassis

## WEIGHTS FOR OPTIONAL EQUIPMENT IN KILOGRAMS (Front – Rear – Total)

Axle Distance	39	41	43
GRS0905	+8 +1 +9	+8 +1 +9	+8 +1 +9
AD1101P Rear axles	0 +57 +57	0 +57 +57	0 +57 +57
Front/Rear anti-roll bars	+33 +51 +84	+33 +51 +84	+33 +51 +84
3 x 29mm f/springs	+44 0 +44	+44 0 +44	+44 0 +44
4 x 28mm f/springs	+73 0 +73	+73 0 +73	+73 0 +73
315/80 tyres/9.00 rims	0 +72 +72	0 +72 +72	0 +72 +72
385/65 tyres/11.75 rims	+38 N/A +38	+38 N/A +38	+38 N/A +38
Aluminium Wheels			
8.25x22.5	-24 -96 -120	-24 -96 -120	-24 -96 -120
9.00x22.5	-30 -120 -150	-30 -120 -150	-30 -120 -150
11.75x22.5	-44 N/A -44	-44 N/A -44	-44 N/A -44
F958-50 frame	+110 +186 +296	+115 +186 +301	+120 +196 +316
Retarder	+72 +17 +89	+73 +16 +89	+73 +16 +89
180Ah Batteries	+14 +3 +17	+14 +3 +17	+14 +3 +17
225Ah Batteries	+46 +10 +56	+46 +10 +56	+46 +10 +56
Std. Tank Full	+133 +91 +224	+137 +87 +224	+141 +83 +224
*2 x 300L G	+160 +146 +306	+166 +140 +306	+172 +134 +306
CP14 cab	-35 +2 -33	-35 +2 -33	-35 +2 -33
CP19 sleeper cab	+119 -13 +106	+119 -13 +106	+119 -13 +106
Air deflectors – CP14	+40 +2 +42	+40 +2 +42	+40 +2 +42
– CP16	+39 +3 +42	+39 +3 +42	+39 +3 +42
– CP19	+39 +3 +42	+39 +3 +42	+39 +3 +42
EG Series PTOs	+15 +3 +18	+15 +3 +18	+15 +3 +18
EK Series PTOs	+42 +5 +47	+42 +5 +47	+42 +5 +47

\* Additional to standard tank full of fuel.

### ENGINE PERFORMANCE

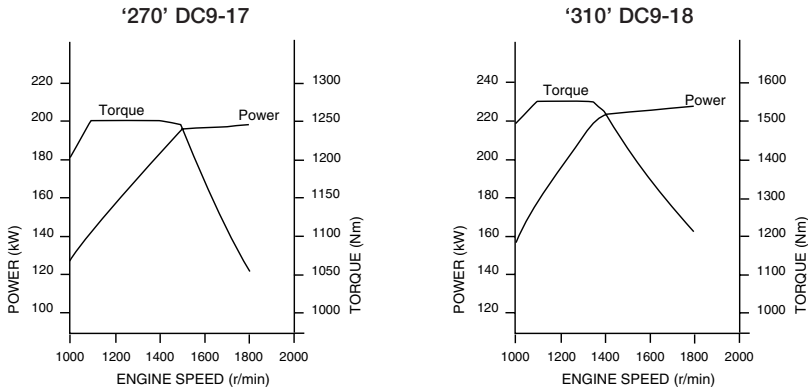

Net engine performance to 80/1269\*1999/99EC

### GEAR STEP DIAGRAM

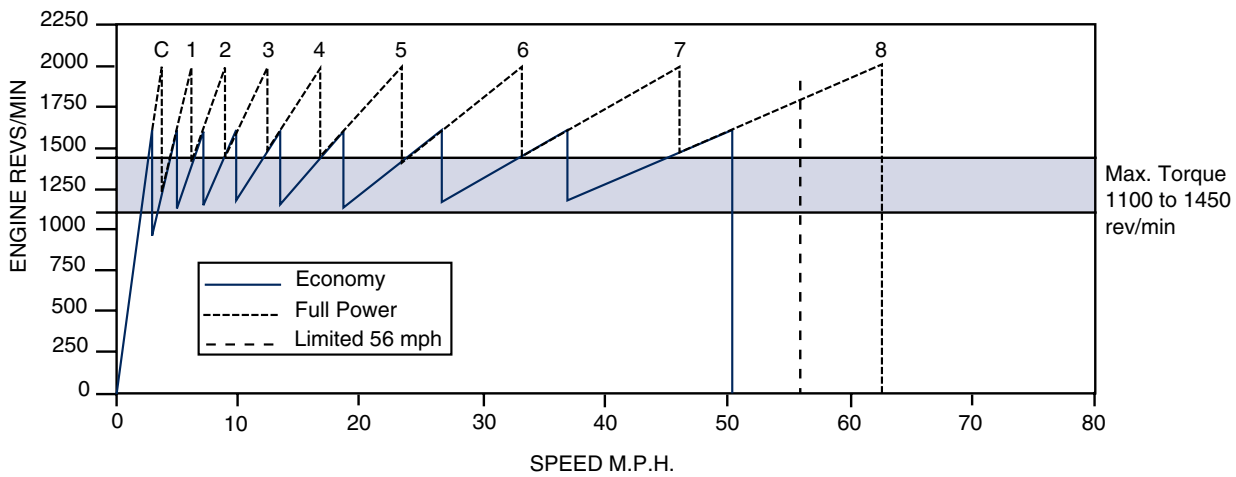

### SPEED/GRADEABILITY

Gradeability may be limited by tyre adhesion.

Axle gear/ Ratio	Optimum Cruising Speed M.P.H.	Gradeability - steady climb - in percent			
		DC9-17		DC9-18	
		26T	44T	26T	44T
RB 660 3.07	54 - 56	>35	25.0	>35	32.1
RB 660 3.42	48 - 51	>35	28.1	>35	>35
RB 660 3.80 std.	44 - 46	>35	31.6	>35	>35
RB 660 4.22	39 - 42	>35	>35	>35	>35
RB 660 4.88	34 - 36	>35	>35	>35	>35

Calculations assume standard specifications. Performance achieved in operation will depend on conditions, bodywork, gear ratios and tyre specification.

**The specifications contained in this publication are intended as a general guide, and not as representations as to the product described, nor as binding in detail.**

